



# Yealink WH66 Mono/Dual

DECT HEADSET

USER MANUAL



JANUARY 2023

# TABLE OF CONTENTS

CLICK ON ANY PAGE NUMBER TO RETURN TO THE TABLE OF CONTENTS

<a href="#">GETTING STARTED</a> .....	1
PACKAGE CONTENTS.	
<a href="#">CONNECTING THE HEADSET</a> .....	2
CONNECT THE HEADSET TO PC OR DESK PHONE, USB CONNECT SOFTWARE.	
<a href="#">CONNECT THE HEADSET VIA BLUETOOTH</a> .....	3
CONNECT TO PC, DESK PHONE OR SMART PHONE	
<a href="#">BASE AND HEADSET CONTROLS</a> .....	4
<a href="#">BASE AND HEADSET SETTINGS</a> .....	6
<a href="#">CALL HANDLING FROM THE HEADSET</a> .....	8
ANSWER, END, REJECT + HOLD.	
<a href="#">CALL HANDLING FROM THE BASE</a> .....	9
ANSWER, END, REJECT + REDIAL FROM MaX UC OR THE DESK PHONE.	
<a href="#">TRANSFER CALLS BETWEEN HEADSET + DESK PHONE</a> .....	10
SWITCH CALLS TO THE HEADSET FROM THE DESK PHONE + THE DESKPHONE TO THE HEADSET	
<a href="#">HANDLING MULTIPLE CALLS</a> .....	10



# YEALINK WH66 MONO + DUAL DECT HEADSET



WH66 Mono



WH66 Dual

## GETTING STARTED

Unbox the contents of the headset.

### PACKAGE CONTENTS

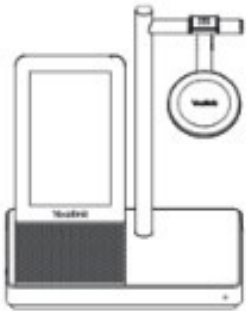

BASE



MONO OR DUAL HEADSET



POWER ADAPTER

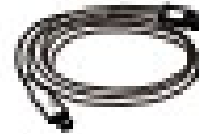

USB-C TO USB-A USB  
CABLE 1.0M



USB-A TO USB-A USB  
CABLE 1.0M

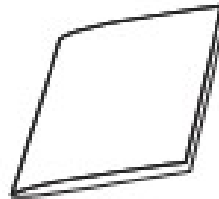

QUICK START GUIDE

**NOTES:** You should use the included accessories as other accessories may have compatibility issues that prevent them from working properly.

Be sure to connect the base to a DC power supply, not just the USB power supply.

The included USB-A to USB-C cable is a specifically provided for connecting the wireless charge (coming soon).

## CONNECTING THE HEADSET

2

The following diagram will assist with connect the headset properly.

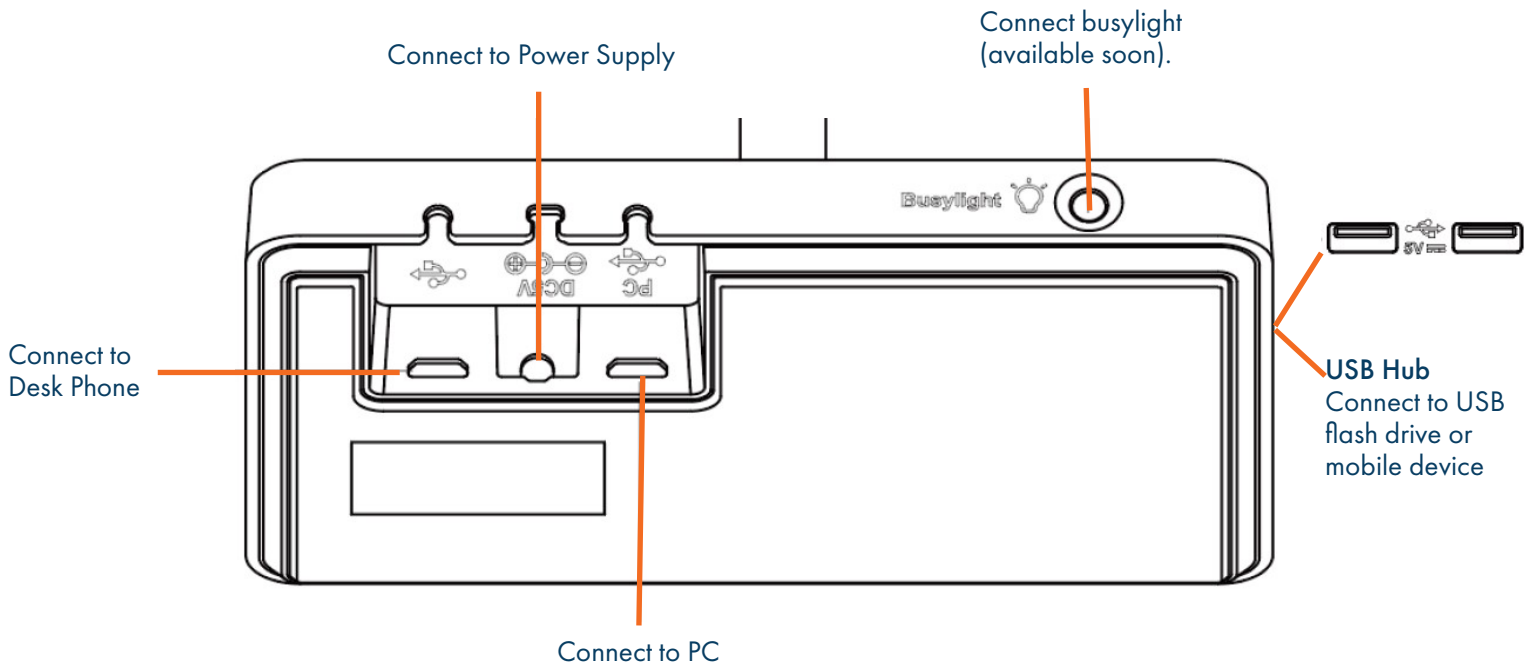

### CONNECT TO PC/DESK PHONE WITH THE INCLUDED USB CABLE

Connect one end of the included USB cable to the PC port on the base and the other end into the USB Port on the PC or desk phone.

**IMPORTANT:** You need to connect the PC to the USB port of the base marked with the text PC.

### CHARGE THE HEADSET BEFORE USE

- + Dock the headset into the charger.
- + Before initial use, dock the headset for at least 30 minutes.
- + For the initial use the headset is successfully paired with the base when you dock it in the base.

## YEALINK USB CONNECT SOFTWARE

Yealink provides a USB device manager client called Yealink USB Connect that can be used to personalize and manage your Yealink Headsets.

Download the software from the Yealink website at <https://www.yealink.com/product/yuc>.

See the separate Yealink USB Connect Quick Reference Guide at [www.northland.net/support](http://www.northland.net/support).

## CONNECT A PC

You can connect the base to a PC via Bluetooth. The Bluetooth range is approximately 100 ft.

**NOTE:** If you connect the base via the built in Bluetooth, the base can only supply voice pickup and audio playback. You will not be able to use the call control features on the headset display.

### PC SETTINGS

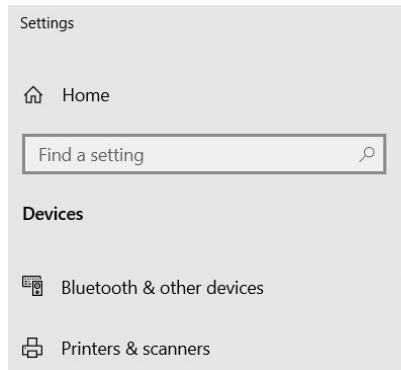

### Bluetooth & other devices

+ Add Bluetooth or other device

Bluetooth  
 On

Now discoverable as "C3ZXQF2"

- + On your PC, go to **Settings > Bluetooth**.  
Be sure Bluetooth is on.
- + On the headset base, tap 
- + Tap **Basic Settings**.
- + Tap **Bluetooth**. The base automatically enters the pairing mode.
- + On your PC, select **Add Bluetooth or other device**.
- + When it appears on the PC display, select **Yealink WH66**.

## CONNECT A DESK PHONE

You can connect the base to a desk phone via Bluetooth. The Yealink T54W and Yealink T58A are both compatible with the WH66 Dect Headset.

- + On the headset base, Tap **Bluetooth**  . The base automatically enters the pairing mode.
- + On your desk phone, turn on Bluetooth and select **Yealink WH66**.

## CONNECT TO A SMART PHONE

You can connect the base to a smart phone via Bluetooth.

- + On the headset base, Tap **Bluetooth**  . The base automatically enters the pairing mode.
- + On your smart phone, turn on Bluetooth and select **Yealink WH66**.

## BASE

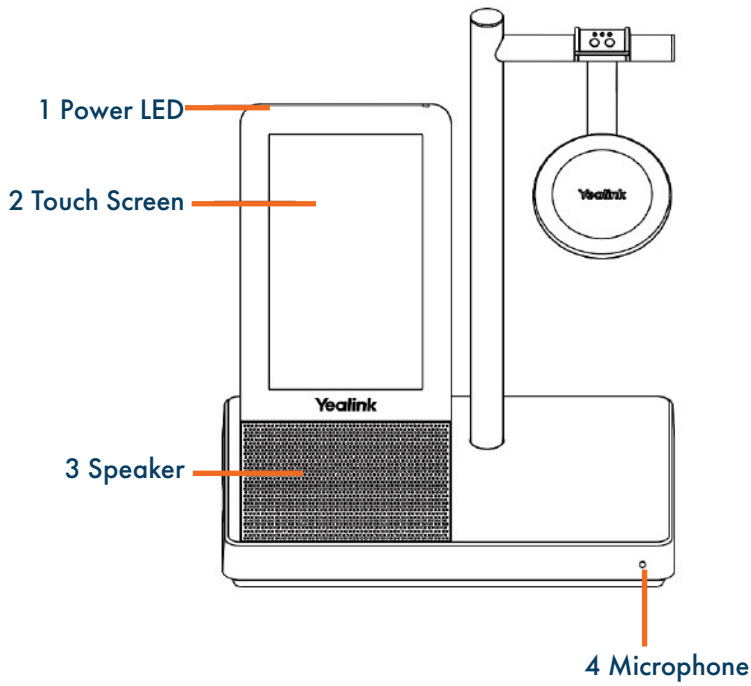

No.	Name	Description
1	Power LED	Indicates the Base status.
2	Touch Screen	<ul style="list-style-type: none"> <li>+ Shows the headset's battery status, headset connection status, etc..</li> <li>+ Select items and navigate menus using the touch screen.</li> </ul>
3	Speaker	Provides hands-free (speakerphone) audio output.
4	Microphone	Provides hands-free (speakerphone) audio output.

## HEADSET

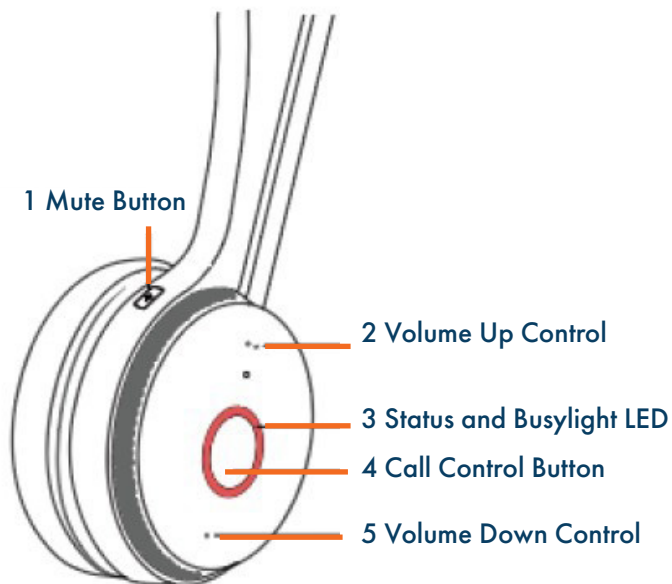

1	Mute Button	Toggles the microphone on or off.
2	Volume Up Control	Raises the in ear volume of the headset.
3	Status and Busylight LED	Indicates charging and call status.
4	Call Control Button	<p><b>Power the headset on or off.</b>                      + Hold for three seconds to power the headset on or off.</p> <p><b>Incoming and active call management</b> depends upon if you have one call or multiple calls.</p> <p><b>One Call:</b>                      + Press once to answer an incoming call.                      + Double-press to reject an incoming call.                      + Press once to end a call.</p> <p><b>Multiple Calls</b>                      + Hold for two seconds to answer an incoming call and put the active call on hold.                      + Hold for two seconds to switch between the held call and active call.                      + Press once to end the current call and answer the incoming call.                      + Double press to stay on the active call and reject the second incoming call.</p>
5	Volume Down Control	Lowers the in ear volume of the headset.

# BASE AND HEADSET SETTINGS

Headset, Base and General Settings can be changed on the WH66 base. You can also change settings using the Yealink USB Connect application.

## CHANGE THE DEFAULT OUTGOING DIALER DEVICE

When there are multiple devices connected to the base, you can select the default outgoing dialer device.

- + Tap the Audio Device card of the device you want to make the default dialer.
- + In the upper right corner, tap ...
- + Tap **Selected as audio device**.

**NOTE:** You will only see ... on the device that is **not** selected as the default dialer.

When using MaX UC, call control must be done through MaX UC and **not** through the headset or base.

## BASIC SETTINGS

- + To work with the headset basic settings, tap 
- + Tap **Basic Settings**.

GENERAL SETTINGS	
Language	Select the screen text language fro a list of 13 languages. (be sure you can read the language).
Bluetooth	Enable/disable Bluetooth.
Add Headset	Add additional headsets to the base. (Up to four).
Time & Date	Set the time and date manually.
Busylight	Available from Northland soon.
DISPLAY SETTINGS	
Backlight	Set the backlight active level and backlight time.
Screensaver	Change the waiting time for the screensaver.
Themes	Change the background and card style.
SOUND SETTINGS	
Ring Tones	Enable/Disable the base to play a built-in tone while receiving an incoming call.
Dial Tone	Enable/Disable the paired headset to play a dial tone when entering the dialing screen.
Keypad Tone	Enable/Disable the paired headset to produce a sound when pressing the keypad keys.
Speaker Volume	Adjusts the playback volume.



## BASIC SETTINGS



+ To work with the headset basic settings, tap

+ Tap **Advanced Settings**.

GENERAL SETTINGS	
Wireless Range	Select the wireless range between the headset and the base. + <b>Long:</b> The wireless range is approximately 500 feet. + <b>Medium:</b> The wireless range is approximately 100 feet. + <b>Short:</b> The wireless range is approximately 33 feet.
Voice Announcement	Enable/disable the paired headset to play voice announcements.
Platform	Available soon from Northland.
CALL SETTINGS	
Auto Dial	Enable/disable the base to automatically dial the entered number within 5 seconds.
Call Device	Select which device to use for outgoing calls.
Call Priority	Select which call takes priority when a second call is presented. + <b>New call:</b> The first call is placed on hold and the new call is active. + <b>Current call:</b> The first call is active and the new call continues to ring.
Autoanswer when Undocked	Enable/disable incoming calls to be answered by undocking the headset
Open Line when Undocked	Enable/disable whether to enter the dialing screen when undocking the headset.
HEARING PROTECTION SETTINGS	
Anti-Startle Protection	Configure which hearing protection technology to use.
Daily Noise Exposure	Configure the daily noise exposure levels. (No limiting, 80dBA or 85dBA).

# CALL HANDLING FROM THE HEADSET

**IMPORTANT:** When using MaX UC, all call control must be done from the MaX UC application and *not* from the headset or base.

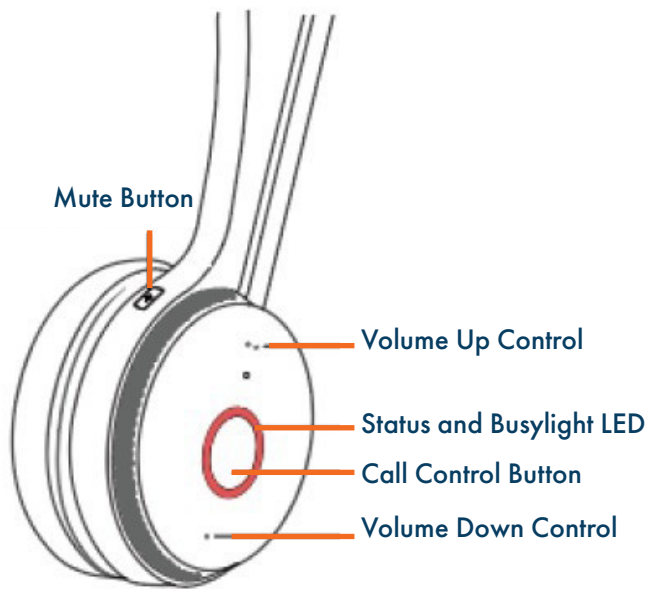

- + **Answer a Call:** Press the Call Control button or undock the headset.  
**NOTE:** Auto Answer must be turned on to answer the call by undocking the headset.
- + **End a Call:** Press the Call Control button or dock the headset.
- + **Reject a Call:** *Double-press* the Call Control button.
- + **Hold a Call:** *Hold* the Call Control button for *two seconds*.
- + **Resume Held Call:** *Hold* the Call Control button for *two seconds*.
- + **Adjust the Volume:** Press the Volume Control button *up/down*.
- + **Mute/Unmute:** Press the Mute button.  
**NOTE:** You can also Mute/Unmute the microphone, by raising and lowering the microphone boom.  
An audible announcement is heard to indicate "Muted" or "Unmuted" status.  
Mute indicator lights illuminate when mute is active.

# CALL HANDLING FROM THE BASE

**IMPORTANT:** When using MaX UC, all call control must be done from the MaX UC application and *not* from the headset or base.

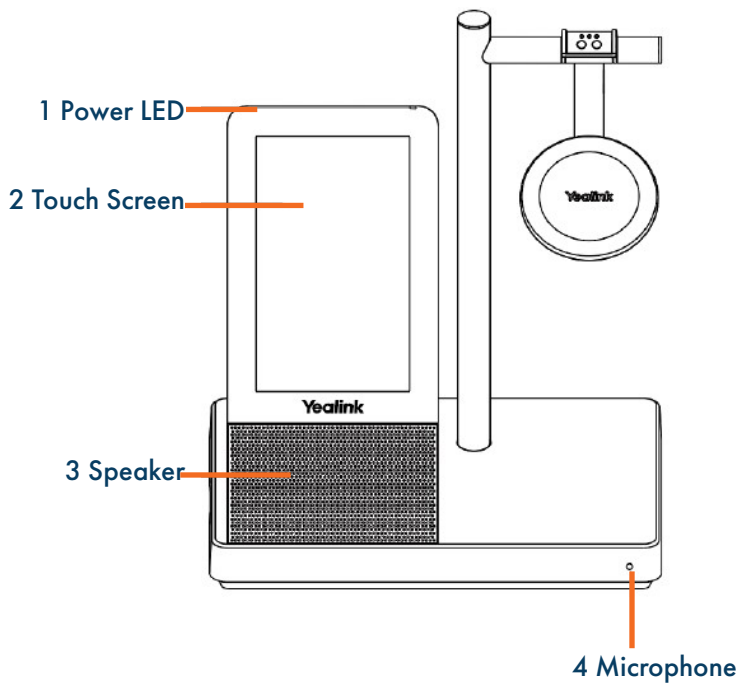

+ **Place a Call:** On the touch screen, *Tap* the card of the device you want to make the call from.

or *Tap* 

Enter the number you want to call.

*Tap* 

+ **Answer a Call:** *Tap* 

+ **End a Call:** *Tap* 

+ **Reject a Call:** *Tap* 

+ **Silence a Call:** *Tap* 

+ **Hold a Call:** *Tap* 

+ **Resume Held Call:** *Tap* RESUME.

+ **Adjust Volume:** *Tap*  or 

+ **Mute/Unmute Microphone:** *Tap*  

**NOTE:** You can also Mute/Unmute the microphone, by raising and lowering the microphone boom.

An audible announcement is heard to indicate “Muted” or “Unmuted” status.

Mute indicator lights illuminate when mute is active.

+ **Place a Second Call:** *Tap*  and then *Tap* New Call.

## MOVE A CALL FROM THE DESK PHONE TO THE HEADSET

### BEFORE YOU BEGIN:

- + The call is answered on the desk phone using the handset or speaker phone.

### PROCEDURE:

- + **Press the Headset Key** on the desk phone.  
The audio will transfer from the desk phone to the headset.

## MOVE A CALL FROM THE HEADSET TO THE DESK PHONE

### BEFORE YOU BEGIN:

- + The call is answered on the headset.

### PROCEDURE:

Do one of the following on the desk phone:

- + Pick up the handset.
- + Press the speaker key.

The audio will transfer from the headset to the desk phone.

## HANDLE MULTIPLE CALLS FROM HEADSET

- + **End Current Call and Answer Incoming Call:** *Press* the Call Control button.
- + **Place Current Call on Hold and Answer Incoming Call:** *Hold* the Call Control button for *two seconds*.
- + **Between Held Call and Active Call:** *Hold* the Call Control button for *two seconds*.
- + **Reject the Incoming Call While on an Active Call:** *Double-press* the Call Control Button.